

DIMENSIONE - DIMENSION

MAX. CONDITIONS



32°C



60 UR%

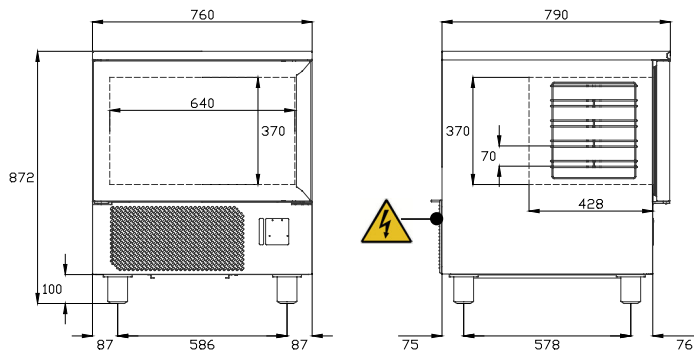
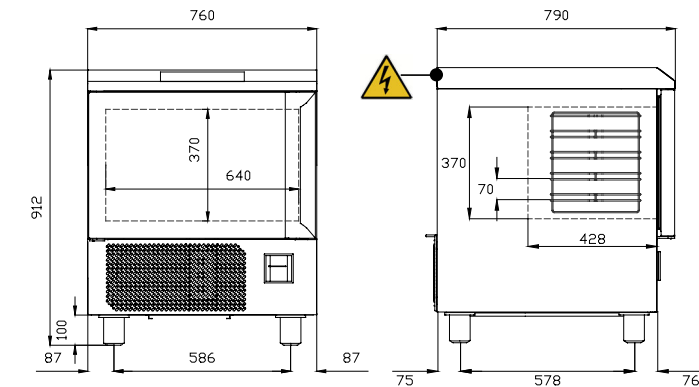

Basic



USCITA CAVO DI ALIMENTAZIONE
ELECTRICAL CONNECTION

COMPANY
WITH QUALITY MANAGEMENT
SYSTEM CERTIFIED BY DNV
= ISO 9001 : 2000 =

AFINOX

QUALITY PERFORMANCE IN REFRIGERATION

RANGE



+3°C / -18 °C

AMX - 5T

Specifiche Tecniche - Specifications - Technische Daten - Données Techniques - Dato Técnicos

230 V / 50 Hz			230V/1N/50HZ	230V/1N/50HZ
Codice prodotto Item code no	Produkt-Kode-Nr. Nr. de code du produit	inox*rostfr.St s/s*inox	9AMX05B....	9AMX05C....
Lunghezza esterna Outside length	Aussenlänge Longueur extérieure	mm	760	760
Altezza Height	Höhe Hauteur	mm	872	912
Profondità Depth	Tiefe Profondeur	mm	790	790
Capacità Capacity	Inhalt Capacité	GN 1/1 EN 600x400	5	5
Compressore Compressor	Kompressor Compresseur	ASPERA	T2178GK	T2178GK
Resa abbattimento Output chilling	Ergiebigkeit SchnellkühlUNG Rendement refroidissement	kg (t = 90') +70°C/+3°C	20	20
Resa surgelazione Output freezing	Ergiebigkeit Sockfrostung Rendement congelation	kg (t = 270') +70°C/-18°C	12	12
Potenza frigorifera Refrigeration power	Kalorienleistung (-10°C,+45°C) Puissance frigorifique	kcal/h W	1536 1787	1536 1787
Fluido refrigerante Refrigerant fluid	Kältemittel Gas frigorigène	kg	R 404A 1,2	R404A 1,2
Centralina elettronica Electronic central unit	Elektronisches Steuergehäuse Centrale électronique		BASIC	CHEF
Potenza assorbita Absorbed power	Leistungsaufnahme Puissance absorbée	W	1070	1070
Rumorosità Noise	Lautstärke Bruit	db	59	59
Peso Weight	Gewicht Poids	Kg	117	117