

**DIMENSIONE - DIMENSION**

MAX. CONDITIONS



25°C



60 UR%

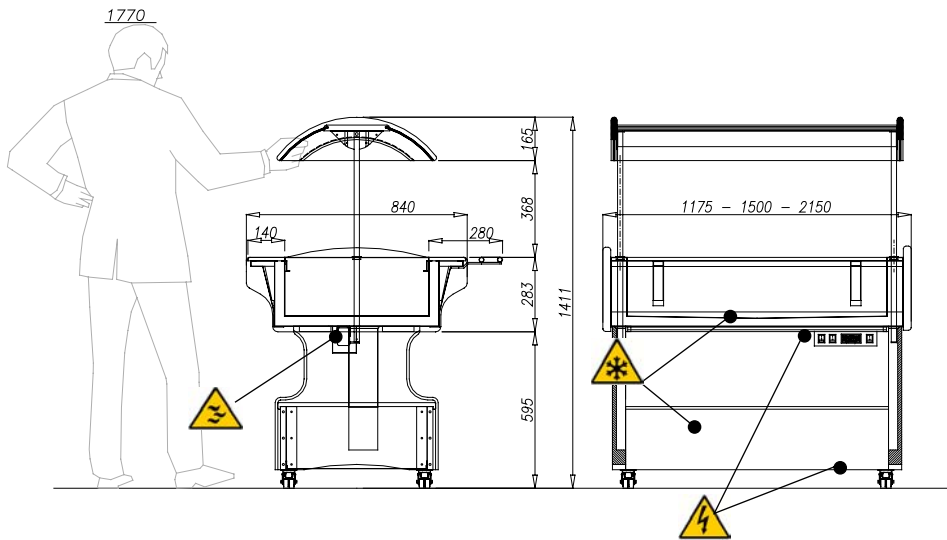

uscita cavo di alimentazione  
electrical connection



scarico acqua  
water outlet



circuito refrigerante  
refrigeration circuit

RANGE



0°C / +7°C

COMPANY  
WITH QUALITY MANAGEMENT  
SYSTEM CERTIFIED BY DNV  
= ISO 9001:2000 =

**AFINOX**

QUALITY PERFORMANCE IN REFRIGERATION

**COLD SAMOA**

**Specifiche Tecniche - Specifications - Technische Daten - Données Techniques - Dato Técnicos**

230 V / 50 HZ			SAMOA 3-1	SAMOA 4-1	SAMOA 6-1
Codice prodotto Item code no	Produkt-Kode-Nr. Nr. de code du produit				
Grezzo - Raw Bianco - White Marr. Chiaro - Light Brown Marr.Scuro - Dark Brown	Unbehandelt - Brut Weiss - Blanc Hellbraun - Brun clair Dunkelbraun - Brun foncé	Codice Code Code Code	9SAM3NFGIE001 9SAM3NFBIE001 9SAM3NFCIE001 9SAM3NFSIE001	9SAM4NFGIE001 9SAM4NFBIE001 9SAM4NFCIE001 9SAM4NFSIE001	9SAM6NFGIE001 9SAM6NFBIE001 9SAM6NFCIE001 9SAM6NFSIE001
Lunghezza esterna Outside length	Aussenlänge Longueur extérieure	mm	1175	1500	2150
Profondità Depth	Tiefe Profondeur	mm	840	840	840
Capacità Storage capacity	Inhalt Capacité	GN	3 GN 1/1	4 GN 1/1	6 GN 1/1
Compressore Compressor	Kompressor Compresseur	ASPERA	NB 6152 GK	NB 6152 GK	NB 6165 GK
Potenza frigorifera Refrigeration Power	Kalorienleistung (-10°C/+45°C) Puissance Frigorifique	kcal/h W	357 415	357 415	437 509
Fluido refrigerante Refrigerant fluid	Kaltemittel Gas Frigorigène	kg	R404a 0,21	R404a 0,21	R404a 0,38
Capillare Capillary	Kapillarrohr Capillaire	diam. mm	1,24 mm - 0,049" 2200	1,24 mm - 0,049" 2200	1,24 mm - 0,049" 2500
Ventilatore Condensatore Condensator Fan	Kondensatorlüfter Ventilateur du condensateur	W	10	10	10 X 2
Illuminazione Lighting	Beleuchtung Eclairage	W	36	36	58
Centralina elettronica Electronic central unit	Elektronisches Steuergehäuse Centrale électronique	ELIWELL CAREL	ID 961 H/C PJ 32 S	ID 961 H/C PJ 32 S	ID 961 H/C PJ 32 S
Potenza assorbita Absorbed power	Leistungsaufnahme Puissance absorbée	W	396	396	450
Rumorosità Noise	Lautstärke Bruit	db(A)	50	50	55
Peso Weight	Gewicht Poids	Kg	125 (150)	148 (175)	186 (266)