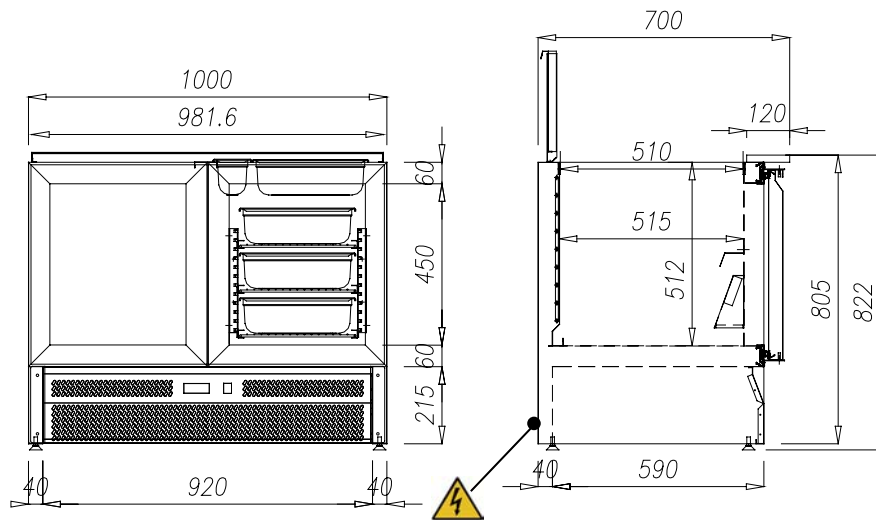

DIMENSIONE - DIMENSION
MAX. CONDITIONS

25°C

60 UR%

 USCITA CAVO DI ALIMENTAZIONE
 ELECTRICAL CONNECTION

RANGE

+2°C / +7 °C

 COMPANY
 WITH QUALITY MANAGEMENT
 SYSTEM CERTIFIED BY DNV
 = ISO 9001:2000 =

AFINOX

QUALITY PERFORMANCE IN REFRIGERATION

SRE
Specifiche Tecniche - Specifications - Technische Daten - Données Techniques - Dato Técnicos

230 V / 50 Hz			
Codice prodotto Item code no	Produkt-Kode-Nr. Nr. de code du produit	inox*rostfr.St s/s*inox	9SRE602GNN
Range		°C	+2 °C / +7 °C
Lunghezza esterna Outside length	Aussenlänge Longueur extérieure	mm	1000
Altezza Height	Höhe Hauteur	mm	830
Profondità Depth	Tiefe Profondeur	mm	700
Capacità Capacity	Inhalt Capacité	dm ³	170
Compressore Compressor	Kompressor Compresseur	ASPERA	NB6152GK
Potenza frigorifera Refrigeration power	Kalorienleistung (-10°C) Puissance frigorifique	kcal/h W	357 415
Fluido refrigerante Refrigerant fluid	Kältemittel Gas frigorigène	kg	R 404A 0,220
Capillare Capillary	Kapillarrohr Capillaire	diam. mm	0,91 3000
Ventilatore del cond. Condenser fan	Kondensatorlüfter Ventilateur du condensateur	W	10
Ventilatore dell' evap. Evaporator fan	Verdampferlüfter Ventilateur de l'évaporateur	W	9/7
Centralina elettronica Electronic central unit	Elektronisches Steuergehäuse Centrale électronique	CAREL ELIWELL	PJ32S ID 961 H/C
Potenza assorbita Absorbed power	Leistungsaufnahme Puissance absorbée	W	550
Consumo giornaliero/24h Daily consumption/24h	Tagesverbrauch/24h UNI EN 441-9 Consommation par jour/24h		5,5
Rumorosità Noise	Lautstärke Bruit	db	50
Peso Weight	Gewicht Poids	Kg	78 (87)

 -Dati tecnici e caratteristiche soggetti a cambiamenti senza preavviso
 -All specification subject to change without notice

 -Technische Daten und Eigenschaften mit Änderungen ohne Anzeige
 -Données techniques et caractéristiques sujettes à des changements sans avis

SRE902.. MOT-01