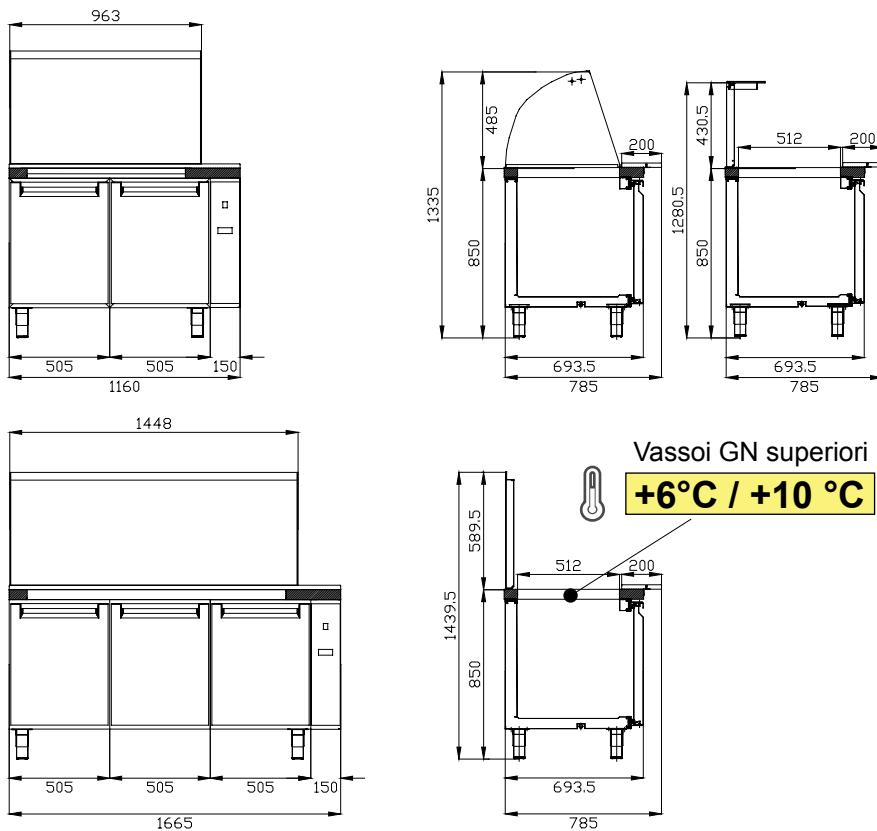

**DIMENSIONE - DIMENSION**

**MAX. CONDITIONS**

**32°C**

**60 UR%**

**RANGE**

**-1°C / +7°C**

COMPANY  
WITH QUALITY MANAGEMENT  
SYSTEM CERTIFIED BY DNV  
= ISO 9001:2000 =

# AFINOX

QUALITY PERFORMANCE IN REFRIGERATION

## SRX 602-3 TN REM

**Specifiche Tecniche - Specifications - Technische Daten - Données Techniques - Dato Técnicos**

230 V / 50 Hz			SRX 602 R	SRX 603 R
Codice prodotto Item code no	Produkt-Kode-Nr. Nr. de code du produit	inox*rostfr.St s/s*inox	9SRX62RPN..	9SRX63RPN..
Lunghezza esterna Outside length	Aussenlänge Longueur extérieure	mm	1160	1665
Altezza Height	Höhe Hauteur	mm	1335	1335
Profondità Depth	Tiefe Profondeur	mm	790	790
Capacità Capacity	Inhalt Capacité	dm <sup>3</sup>	300	450
Compressore Compressor	Kompressor Compresseur		-	-
Potenza frigorifera Refrigeration power	Kalorienleistung (-10°C) Puissance frigorifique	kcal/h W	- -	- -
Fluido refrigerante Refrigerant fluid	Kältemittel Gas frigorigène	kg	R 404A -	R 404A -
Capillare Capillary	Kapillarrohr Capillaire	Mod. Orif.	TS2 00	TS2 00
Ventilatore del cond. Condenser fan	Kondensatorlüfter Ventilateur du condensateur	W	-	-
Ventilatore dell' evap. Evaporator fan	Verdampferlüfter Ventilateur de l'évaporateur	W	14/15	14/15
Centralina elettronica Electronic central unit	Elektronisches Steuergehäuse Centrale électronique	CAREL ELIWELL	PJ32S ID961 H/C	PJ32S ID961 H/C
Potenza assorbita Absorbed power	Leistungsaufnahme Puissance absorbée	W	44	66
Consumo giornaliero/24h Daily consumption/24h	Tagesverbrauch/24h Consommation par jour/24h	kWh/24h	-	-
Rumorosità Noise	Lautstärke Bruit	db	-	-
Peso Weight	Gewicht Poids	Kg	85 (98)	120 (138)

-Dati tecnici e caratteristiche soggetti a cambiamenti senza preavviso  
-All specification subject to change without notice

-Technische Daten und Eigenschaften mit Änderungen ohne Anzeige  
-Données techniques et caractéristiques sujettes à des changements sans avis

**SRX 602-3 REM-00**